

Aspen FP2132 5L Hot Water Pump

Heavy Duty Condensate Pump 100°C

The Hot Water Heavy Duty pump is designed to handle 100°C water and with an outstanding 1800L/h water flow rate. No job is too big!



KEY FEATURES

- 1800L/h max. flow
- 15m max. rec. head (flow rate 10L/h)
- High flow rate
- Handles 100°C water • Non-return valve
- Easy installation

SUITABILITY

- Up to 2400kW / 8m Btu/h
- Air handling units (AHUs); Humidifiers, Boilers; Refrigeration

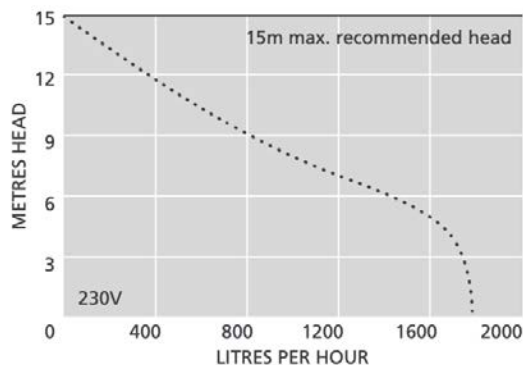
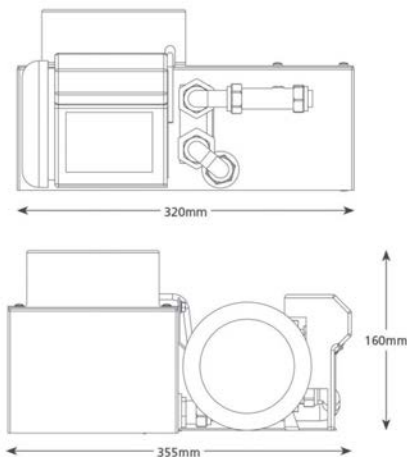

HOT WATER HEAVY DUTY SPECIFICATIONS

Max. flow	1800L/h @ 0 head
Max. rec. head	15m
Tank capacity	5L
Sound level@1m	63dB(A)
Power supply	230V AC 50-60Hz 1.5A
Rated	Non continuous
Class	I appliance
Max. unit output	2400 kW / 8m Btu/h
Max. water temp	80°C / 176°F
Inlet/outlet size	x2 40mm in, 15mm out
IP Protection	IPX1
Safety switch	4.0A Normally closed
Thermal protection	✓
Fully potted	n/a
Self priming	n/a

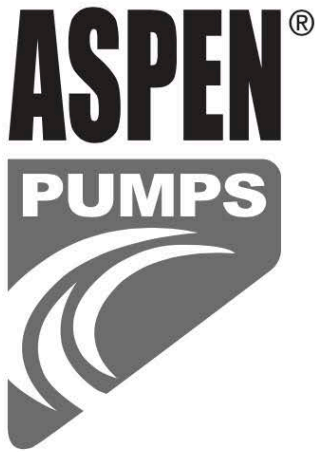

The Aspen Stainless Steel Hot Water Tank Pump

Suitable for any humidifier drain-down applications

Description

The pump is designed to collect hot water from humidifier drain down cycles and the normal condensate from any associated air conditioning or boiler systems and discharges it to a maximum head of 15 metres.

The internal prewired safety float is a low current switch to stop the drain down cycle in the event of pump failure. The pump is operated via an internal float switch.

Dimensions

Height: 160, Width: 360mm, Depth: 325mm

Installation Notes

This pump is designed to sit on a level surface.

15mm copper is recommended for the discharge, keeping the number of elbows to a minimum and should be lagged to prevent freezing.

Additional check valves may be required to prevent siphoning if pipework falls away to a lower level.

INSTALL SHEET

Technical Specification

- 2 metre connecting cable
- Pre-wired safety switch 240V, 3A max
- Maximum water pumping capacity 30 litres/minute
- Non-return valve
- Tank holds 5 litres
- Max. discharge head 15 metres
- Pump rating 240V AC, 1.1A full load

Electrical Connections

Brown	Live
Blue	Neutral
Green/yellow	Earth
2 x Black	Safety Float Switch

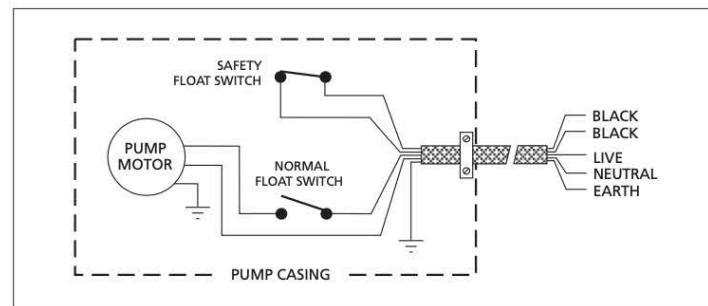

Commissioning the Pump

- 1 Fill the tank with cold water.
- 2 Disconnect the external non-return valve.
- 3 Depress internal non-return to prime pump.
- 4 Reconnect the external non-return valve.
- 5 Connect power supply -pump should run
- 6 Check the pump switches are OFF when empty.

Service Guide

The pump should be cleaned on a regular basis to remove all scale deposits and ensure free operation of all float switches.

The pump should then be recommissioned with clean cold water.

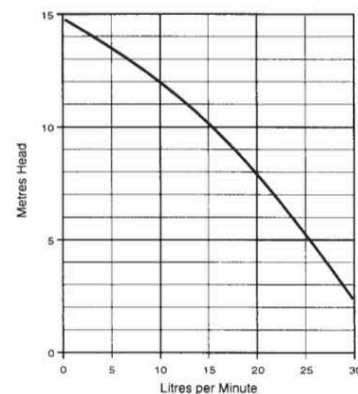

Manufactured in the UK by Aspen Pumps®